

The leading edge of excellence

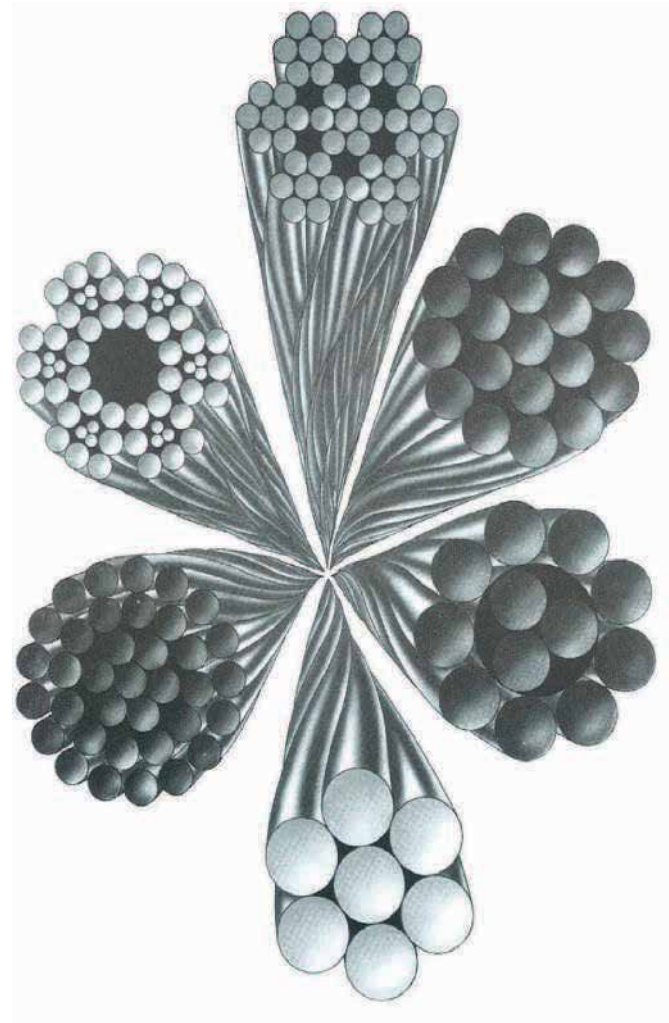

RIGGING PRODUCT CATALOGUE

STEEL WIRE ROPE



Ropes available in various diameters, constructions and finishes.

Manufactured to various international standards.

COMPONENT PARTS OF WIRE ROPE

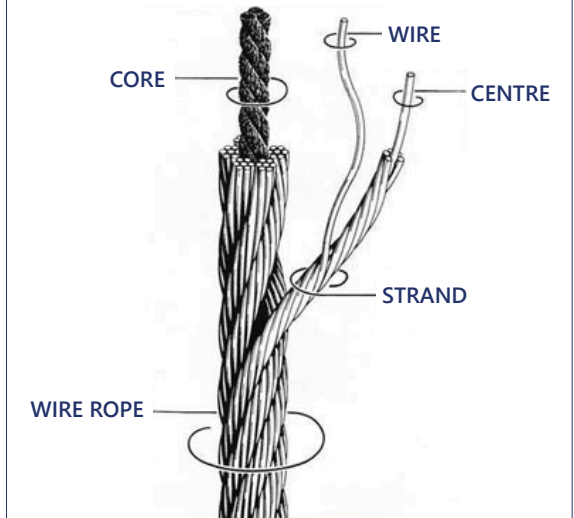

Enquire about our range of 8x19, 8x26 and 35x7 Compacted strands, 2160mpa high performance ropes

STEEL WIRE ROPE SLINGS



Bespoke steel wire rope slings manufactured to suit your requirements.



- Manufactured to international specifications
- Afgrip slings manufactured with seamless extruded ferrules from Germany
- Can be proof loaded individually at additional cost
- 6:1 Safety factor as required by the Occupational Health and Safety Act
- Stainless steel slings also produced to customer requirements
- DNV certified slings available on request

HOW TO ORDER A VITALIFT STEEL WIRE ROPE SLING (PLEASE SPECIFY):

- **Type of sling required** (one leg, two legs, etc)
- **WLL limit required**
(See chart overleaf for standard slings).
- **Type of splice:**
Afgrip (also know as Turn-Back, or Aluminium)
Superloop (also know as Flemish, National, or Jupiter)
- **Effective length**
(leg length / pull to pull length / circumference)
- **Finish of steel wire rope required:**
Ungalvanised, galvanised or stainless steel
- **Whether eyes are soft (standard) or should have thimbles (hard)**
- **Eye sizes for soft eyes**
(see standard eye sizes on chart overleaf)
- **Serial numbers required**
- **Any fittings required**



GRADE 80 & 100 CHAIN SLINGS



Chain slings are the classic and widely used load handling attachment for a wide variety of lifting applications.

They feature flexibility and extremely high durability.

Premium quality chain slings assembled with Thiele chain made in Germany.

We offer complete chain slings and components in grades 80 & 100 as well as corresponding accessories and spare parts.

Chain slings made to order according to your requirements.

All lifting components are uniformly marked with equivalent chain size and grade.

Safety factor: 4:1

1 LEG SLING
(Grade 80 Shown)



2 LEG SLING
(Grade 100 Shown)

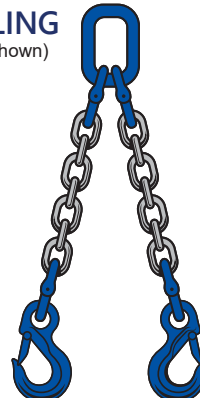

3 LEG SLING
(Grade 80 Shown)



4 LEG SLING
(Grade 100 Shown)



Assembled with chain from:

THIELE



Made in Germany



GRADE 80 CHAIN SLINGS



Chain slings are the classic and widely used load handling attachment for a wide variety of lifting applications.

They feature flexibility and extremely high durability.

NEW PRODUCT TO OUR RANGE

We offer complete chain slings and components as well as corresponding accessories and spare parts.

Chain slings made to order according to your requirements.

All lifting components are uniformly marked with equivalent chain size and grade.

Safety factor: 4:1



1 LEG SLING



3 LEG SLING



2 LEG SLING

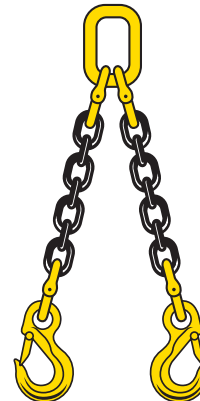

4 LEG SLING





WEBBING SLINGS

Versatile and lightweight multiple leg webbing slings now available with quicker delivery.

NEW PRODUCT TO OUR RANGE



Webbing slings with special Grade 80 components ideal for applications where damage to the item being lifted needs to be minimised.

Easier handling compared to chain slings.

Webbing connectors enable easy attachment of webbing slings to master links, eye sling hooks or eye self-locking hooks.

IEWJ SLING JOINER

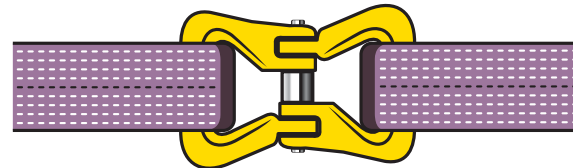

Grade 80 Sling Joiner to connect two webbing slings or to make webbing slings endless.

1 LEG SLING



2 LEG SLING

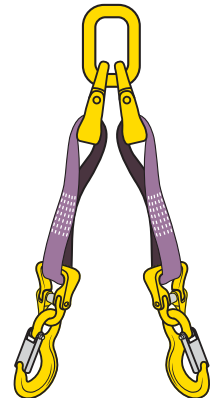

3 LEG SLING

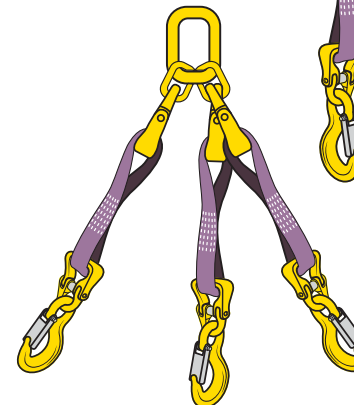

4 LEG SLING

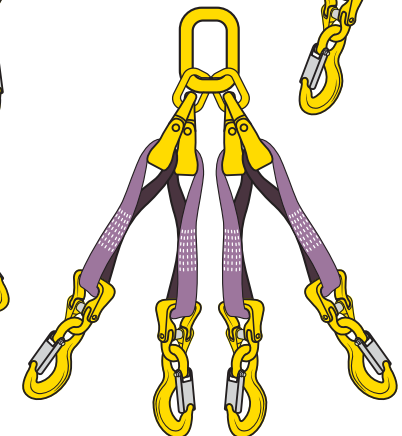

DUPLEX FLAT WEBBING & ENDLESS ROUND SLINGS



Manufactured to EN1492 and SANS94



- Slings colour coded to WLL for easy identification
- All slings are manufactured to comply with:
(EN1491-1 and SANS94-1 Flat woven webbing slings
EN1491-2 and SANS94-2 Roundslings)
- Safety factor 7:1 in compliance with standards and the Occupational Health and Safety Act
- Each sling serial numbered for traceability
- Common sizes available ex-stock, larger capacity slings can be manufactured to order

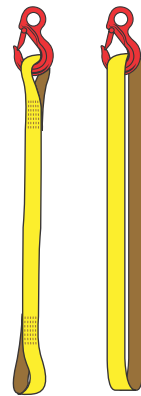

VERTICAL SLING

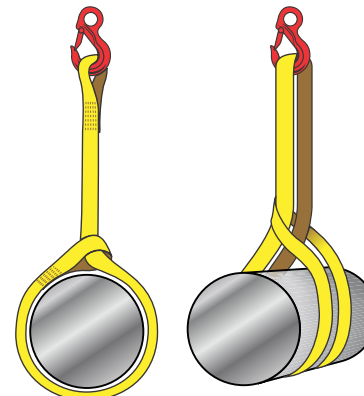

CHOKER SLING

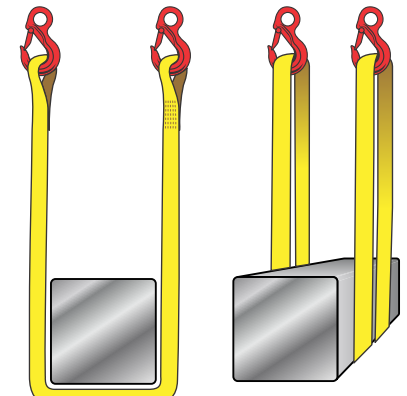

PARALLEL BASKET SLING

Slings with higher working load limits available on request

Due to our policy of continual product development, dimensions, weights and specifications may change without prior notice. Please check with your sales representative when ordering.

FITOP ELECTRIC HOISTS & MOTORIZED CRAWLS



- Low headroom design
- High duty cycle, 360 starts per hour standard.
- Heavy duty hoist motor with class H insulation.
- Ideal lifting speeds.
- High output motors.
- Negative phase detector.
- True modular design
- Grade 80 super alloy load chain, 6 to 1 safety factor.
- Chain bag standard.
- The unique D.C brake design does not break the kinetic bond between the holding brake and the lifted load. The brake design also incorporates a manual release mechanism in case of power failure.
- Overload protection via advanced external slip clutch.
- Sealed electrical enclosure.
- Upper and lower paddle type limit switch has built- in chain guides.
- Lightweight pendant is double insulated and ergonomically designed.
- 48 volt low - voltage control standard.
- Motorized crawl includes D.C disc brake and control
- Motorized crawl hoists are supplied with a four-button pendant control.
- Standard voltages: 380v/ 50Hz, and 525/50Hz

ELECTRIC CHAIN HOIST



Electric Chain Hoist 1 Ton, 2 Ton & 3 Ton Single Fall, Single Speed

MEU020S380
2 Ton Hoist



MEU010S380
1 Ton Hoist



MEU030S380
3 Ton Hoist



- Hoist Body: Manufactured from lightweight aluminium which is rigid allowing for use in extreme working conditions. The design of the cooling fins offers rapid heat dissipation to prevent overheating
- Phase protection relay: Unit will not operate if phases are incorrectly connected
- Limit switch: Durable limit switch device is installed to make the motor stop automatically when safety limits are exceeded
- Side magnetic braking device: The braking device will instantly brake in the case of a power failure or interruption
- Chain bag: The bags are lightweight and durable
- Chain: The chain is imported case hardened grade 80 steel alloy chain
- Pendant control: 48V pendant control for operator safety. The push button is light and durable with an emergency mains cut out
- Hook: Bottom hook rotates 360 degrees and is fitted with a safety latch



BUILDERS HOIST



FEATURES:

- Compact and lightweight design
- Easily mounted
- Limit lever switch prevents over - winding
- Double brake system
- Plug in connections for maximum portability
- Complete with 360 - universal joint saddle hook
- Compact and lightweight design

- ▶ **SUPER MINI**
- ▶ **SUPER LIGHT**
- ▶ **HIGH SPEED**
- ▶ **HIGH PERFORMANCE**

MODEL	DU - 250A
CAPACITY	250KG
SPEED	15M / Min
OUTPUT	1.3 kW
VOLTAGE	220V SINGLE PHASE
ROPE	5mm, 6x19, FC GALV.
MAX LIFT	60MM
DUTY CYCLE	30%
HEADROOM	700mm
NET WEIGHT	20KG





PROLH LEVER HOIST

The professionals' choice incorporating our patented twin cam pawl design.



PROLH lever hoists incorporate many of the advanced safety features that Tiger has developed, including their own unique dual brake mechanism that automatically engages when the lever hoist feels the slightest resistance on the bottom hook.

This key feature means that the PROLH will raise, hold, and lower the lightest of loads without slipping.

The two stage process protects against accidental light load failures caused by putting the hoist into neutral whilst under load.

This includes operations that require a hoist to be used horizontally, inverted, or at any angle.

The PROLH is ideally suited for applications in the overhead transmission industry, shipyards, offshore platforms and is also suitable for underground mining use.

These units meet and exceed all the requirements within BS EN 13157:2004, ANSI/ASME B30.21-2005, AS1418.2 and SANS 1636.

- Range 800kg - 20000kg
- Equipped with our unique dual brake mechanism
- One piece construction pinion gears
- Overload protection available
- Adaptable to use both inverted and horizontally
- *NEW* Patented Twin Cam shaped pawl design
- Light load tested and certified at 2% of the rated capacity and proof tested at 1.5 times the rated capacity
- Operating temperature range of -40°C to +50°C
- SANS 1636 compliant



Drop forged and heat treated wide opening alloy hooks incorporating heavy duty latch kits that fully engage into the nose of the hook offering maximum load security.



Chain stripper specifically designed to guide the load chain safely onto or off the load sheave without snagging or jamming, allowing safe use in any orientation.



Unique dual brake mechanism with anti-tamper design, shown in "freewheel" and "brake engaged" positions. Available with overload protection.



TCB CHAIN BLOCK

The classic heavy duty light weight chain block.



Shown with optional corrosion resistant load chain.

Manufactured and evolved over 50 years, Tiger chain blocks offer the perfect balance between operator effort and speed of lift, ensuring maximum mechanical efficiency.

The short head room allows for easy installation where space is limited. Using the highest quality steel materials, the TCB is a lightweight, compact and rugged construction. All major components are heat treated and precisely machined to ensure long term smooth operation.

The strong impact resistant gearbox housing has close tolerance fit bearings that fully support the pinion shaft and planet gears, to maintain smooth revolutions under load.

These units meet and exceed all the requirements within BS EN 13157:2004, ANSI/ASME B30.21-2005, AS1418.2 and SANS 1594.

- Range from 500kg - 30000kg
- Double cover protection for brake chamber
- *NEW* Patented Twin Cam shaped pawl design
- Guaranteed 2% light load protection and proof tested to 1.5 times rated capacity
- Overload protection available
- Tested and certified for "fleeting" and "cross - hauling" applications
- Safe reliable independent twin pawl mechanical brake
- Heat treated alloy steel triple spur gears and pinion shaft
- Minimal overhaul effort
- SANS 1594 compliant



Drop forged and heat treated wide opening alloy hooks incorporating heavy duty latch kits that fully engage into the nose of the hook offering maximum load security.



The fine tolerance deep pockets on the hand wheel ensure positive engagement of the hand chain at all times for smooth operation. Overload protection available.



Strong and contoured chain end anchor will hold a load of at least 2.5 times the rated capacity when supporting the full load without restraint from other components e.g. brake or gearing. This prevents accidents, by acting as a stop when the lift length of the load chain is exceeded when lowered.



Recessed forgings offer full protection to the load chain anchor bolts on all our bottom hooks.



SS11 SUBSEA LEVER HOIST

The original and proven subsea lever hoist - constantly developed and improved.



The SS11 has been designed and developed to be certified for safe use Subsea, and is thus also suitable for most harsh and extreme applications.

It comes equipped with a unique dual brake mechanism that automatically engages when the lever hoist feels the slightest resistance on the bottom hook. This key feature means that the SS11 will raise, hold, and lower the lightest of loads without slipping. The two stage process protects against accidental light load failures caused by putting the hoist into neutral whilst under load.

The unique design features and anti-corrosion properties incorporated in the SS11 hoist range, including the one piece construction pinion gears, give it significant safety advantages over standard lever hoists, making the hoist the ideal tool for all marine, mining and other extreme applications.

The SS11 meets and exceeds the requirements of IMCA DQ28 Rev. 1 "Guidance on the use of chain lever hoists in the offshore subsea environment", as well as other industry client specifications whilst conforming to standards such as BS EN 13157:2004, ANSI/ASME B30.21-2005, AS1418.2 and SANS 1636.

- Range from 800kg-20000kg
- *NEW* Patented Twin Cam shaped pawl design
- Unique dual brake mechanism
- One piece construction pinion gears
- No requirement for pre-load tension to activate the ratchet mechanism
- Lifts, holds and lowers the load at 2% of rated capacity so no light load failures
- Over 1000 hours corrosion protection under ASTM B117 salt spray test conditions
- Certified and proven track record
- Overload protection available
- SANS 1636 compliant



Drop forged and heat treated wide opening alloy hooks incorporating heavy duty latch kits that fully engage into the nose of the hook offering maximum load security. Stainless steel fixings and fasteners used throughout the hoist.



Unique dual brake mechanism.



Tiger have incorporated the ultimate safeguarding of a single point failure mode by installing a new specially designed adjustable chain end stop profiled to fit the contours of the hoist body.



Chain stripper specifically designed to guide the load chain safely onto or off the load sheave without snagging or jamming, allowing safe use in any orientation.

This unit can also be supplied to ATEX approved spark resistant specification



SS12 CORROSION RESISTANT CHAIN BLOCK



Unrivalled corrosion protection.



Tiger chain blocks have been manufactured and developed for 50 years and offer the perfect balance between operator effort and speed of lift, ensuring maximum mechanical efficiency.

Using only the highest quality materials precisely machined in our own factory, the SS12 is the ideal block for use in salt water and other corrosive environments, with less maintenance and servicing costs.

The highly efficient and fully corrosion protected twin pawl brake works instantly when the operation is stopped and securely holds the load. Loads are lowered under perfect control, allowing for precise operations.

The SS12 easily passes the "brake lock out test" as per BS 3243:1990 with a 2% load of the rated capacity.

These units meet and exceed all the requirements within BS EN 13157:2004, ANSI/ASMEB30.21-2005, AS1418.2 and SANS 1594.

- Range 500kg–30000kg
- *NEW* Patented Twin Cam shaped pawl design
- Fully corrosion protected body and components - over 1000 hours continuous protection
- Corrosion protected load and hand chain
- Marine specific friction discs
- Double cover protection for brake chamber
- Stainless steel fixings and fasteners
- Guaranteed 2% light load protection
- Overload protection available
- SANS 1594 compliant



Drop forged & heat treated wide opening alloy hooks incorporating heavy duty latch kits that fully engage into the nose of the hook offering maximum load security. Stainless steel fixings & fasteners used throughout the hoist.



Recessed forgings offer full protection to the load chain anchor bolts on all our bottom hooks. Load sheave protected design on all multi fall hooks.



Unique corrosion protection of all the internal parts including load and hand chain, ensuring over 1000 hours continuous protection under ASTM B117 salt spray test conditions.

This unit can also be supplied to ATEX approved spark resistant specification



TIGER UNIVERSAL BEAM CLAMP MODEL NO BCU



This product is not for sale in, use in or importation into the United Kingdom



MAIN FEATURES

- 3.0t and 5.0t capacities available
- Quick and versatile rigging point for hoisting equipment
- Low headroom design
- Highly flexible - for lifting, pulling or as a semi-permanent anchor point
- Designed for both vertical and side loading applications - can be loaded at any angle
- Suitable for pulling and lifting at angles across the beam
- Full rated capacity at any lifting angle
- Designed to accommodate a wide range of beam widths
- Multidirectional adjusting screw spindle ensures a high clamping force to the various flange sizes within its capacity
- Safety factor of at least 5 times SWL
- Operating temperature of -50°C to +50°C
- Complies with ASME B30.20

Warning: Do not exceed working load limits or use this equipment for lifting flat plate sections

 Australia

 Taiwan

 UK



SGS



TIGER ADJUSTABLE ANGLE BEAM CLAMP MODEL NO BCA



- 1.0t and 3.0t capacities available
- Quick and versatile rigging point for hoisting equipment when attached to overhead steel angle section approved for lifting applications
- Shackle suspension point
- V shaped clamping jaws ensures safe and secure grip
- Designed to accommodate a wide range of steel angle sections
- No tools required – integrated adjusting screw spindle

Certification:

Each unit comes fully certified with a test certificate or an EC Declaration of Conformity stating compliance with the essential health and safety requirements of the Machinery Directive 2006/42/EC.

Due to our policy of continual product development, dimensions, weights and specifications may change without prior notice. Please check with your Tiger sales team when ordering.

-  Australia
-  Taiwan
-  UK



TIGER ADJUSTABLE TROLLEY - APT



MAIN FEATURES

- Fitted with a screw spindle which allows easy adjustment and high clamping force to the various flange sizes within its capacity
- Shackle allows for use at angles across the beam
- Designed to provide smooth and easy traversing
- The anti-drop plates design ensures extra safety, and also prevents damage to wheels when contacting end rail stoppers
- Wheels run on sealed ball bearings for smoother rolling with less effort and maintenance
- Trolley Range from 0.5t to 10.0t
- The 5:1 factor of safety allows for use with manual or powered hoists

These units meet and exceed all the requirements within BS EN 13157: 2004+A1:2009 and AS1418.2.

Certification:

Each unit comes fully certified with a test certificate or an EC Declaration of Conformity stating compliance with the essential health and safety requirements of the Machinery Directive 2006/42/EC.

-  Australia
-  Taiwan
-  UK



ILULA CHAIN BLOCK

ILULA®

Robust & dependable chain block that is economical & lightweight



MAIN FEATURES

- Range from 500kg - 20,000kg
- Double pawl braking system
- Extra-thick asbestos-free friction plates
- Anti-slip hooks providing extra safety with heavy duty cast safety latches
- Full spares back-up for maintenance purposes
- Drop forged top & bottom hooks that can rotate 360°
- Designed to international standards. Generally compliant to SANS
- Units can be chained for any height of lift required
- Overload protection available on request
- Each unit is tested to 125% of the rated capacity
- Serial numbered for traceability
- Supplied with individual test certificate

OVERLOAD PROTECTION

Available on request

Assembled & Tested in South Africa

ILULA CHAIN BLOCK

ILULA®

Robust & dependable chain block that is economical & lightweight



MAIN FEATURES

- Range from 750kg - 9,000kg
- Double pawl braking system
- Extra-thick asbestos-free friction plates
- Anti-slip hooks providing extra safety with heavy duty cast safety latches
- Time saving rapid free-wheeling system for fast hook-ups
- Full spares back-up for maintenance purposes
- Drop forged top & bottom hooks that can rotate 360°
- Designed to international standards. Generally compliant to SANS
- Units can be chained for any height of lift required
- Overload protection available on request
- Each unit is tested to 125% of the rated capacity
- Serial numbered for traceability
- Supplied with individual test certificate

OVERLOAD PROTECTION

Available on request

Assembled & Tested in South Africa

ROLACRAWLS



PLAIN



GEARED

MANHOLE-RING LIFTING SYSTEMS



A standard system consists of a three-legged Chain sling attached to three lifting clamps.

- Minimum diameter of ring - 900mm
- Wall thickness range - 40mm to 125mm
- Maximum weight - 2400kg
- Clamps available individually

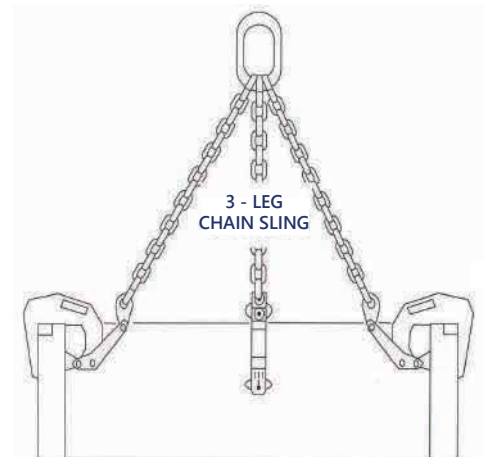

PERSONAL FALL PROTECTION BEAM ANCHORS



Tiger Beam Anchors are used as anchorage connectors for personal fall arrest systems & meet the requirements of SANS 50795 and EN 795



Designed to be attached to Horizontal I-Beams with an attached personal fall arrest system jaw sliding clamp can also be attached to vertical I-Beams.

(full body safety harness, shock absorbing lanyard or fall arrest block).

The Tiger single Minimum breaking strength 22.3kN

Designed for one person use only with a maximum capacity of 140kg

Model Number

FABASJ

Single Jaw Sliding
Fixed Beam Anchor



Model Number

FABART

Mobile Two Jaw Sliding
Mobile Beam Anchor



Model Number

FABADJ

Two Jaw Sliding
Fixed Beam Anchor



Beam Anchors for larger beams available on request

FALL ARRESTORS

A range of retractable lifelines that reduces the shock loading on the body by limiting the distance of fall.

Used in work inspection, general construction, maintenance, oil production, telecommunications, mining and confined work areas.

HARU® Fall Arrestors provide continuous protection against falls.

The Fall Arrestor automatically extends and retracts to allow freedom of movement.

Each unit includes anchorage ropes.

HARU® Fall Arrestors are manufactured in a ISO 9001:2008 factory and all products are CE approved.



Patented Safety Mechanism



FAHB06N



FAHB10
FAHB06



FAHB15



FAHB20

For confined space and rescue applications. Adjustable height.
Additional cable pulley and point to attach to retractable lifeline. For manhole max. diameter 1.5m and under.



LIFTING APPLIANCES

DRUM LIFTERS



VERTICAL RING



DRUM HOOKS



VERTICAL



HORIZONTAL

BEAM CLAMPS

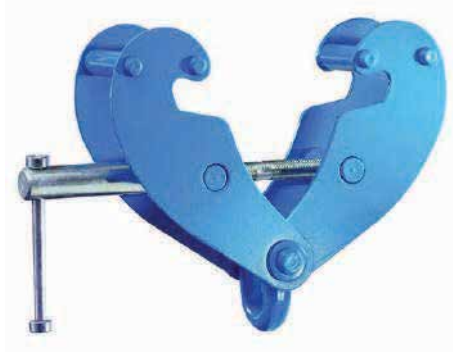

BEAM CLAMPS

FORKLIFT HOOKS

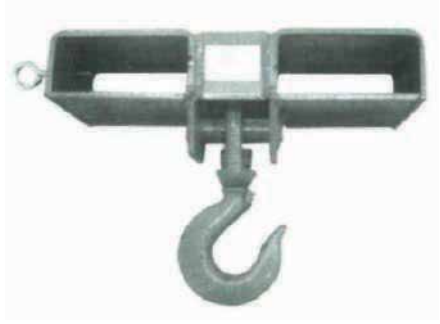

FORKLIFT HOOKS



IMPERIAL OFFSHORE
- MARINE SERVICES AND SUPPLY -



CONTAINER LIFTING SYSTEMS

For lifting partially filled or empty six metre containers

Standard System Capacities

- 3 Tons
- 6 Tons
- 10 Tons

Lugs are available as separate items

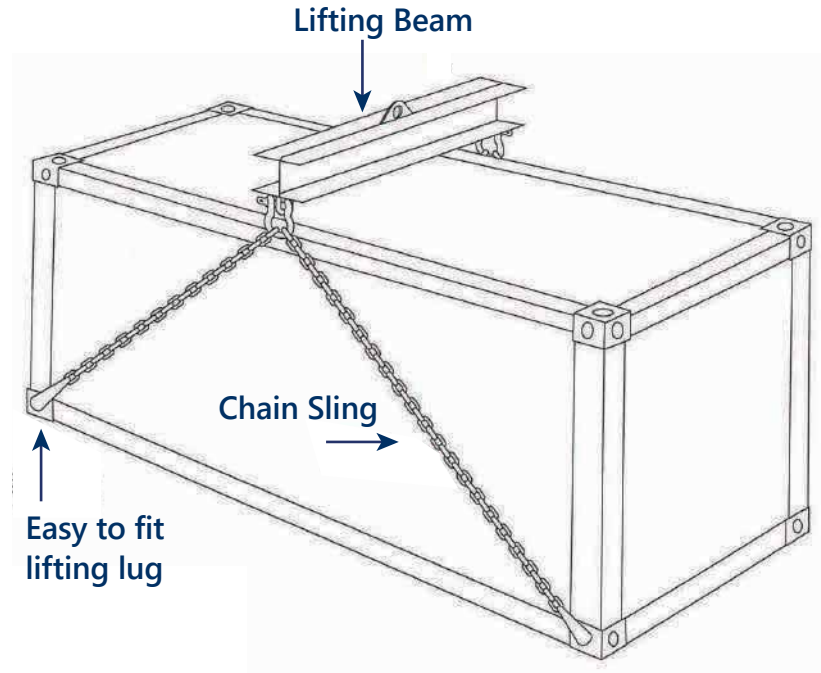

LEFT HAND

RIGHT HAND

VERTICAL

Working load limit per lug - 12500kg | safety factor 4 : 1



VITALIFT PLATE GRABS



VERTICAL



UNIVERSAL



HORIZONTAL

MAXIGRAB PLATE GRABS



VERTICAL



UNIVERSAL



HORIZONTAL





MAXIMAG LIFTING MAGNETS

HAND WINCHES

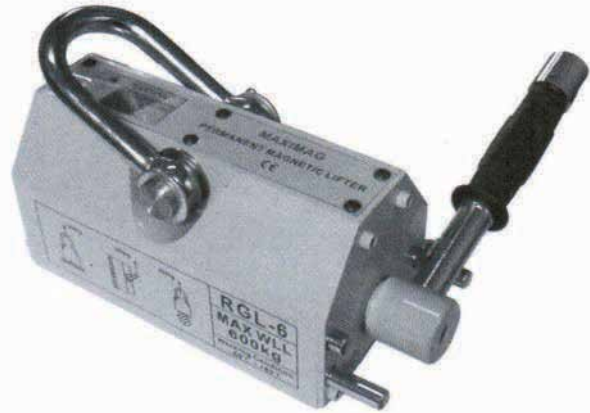

- 3,5 : 1 Safety Factor
- Simple locking switch enables one handed operation
- V-slot in lifting fave allows for lifting of flat and rounded surfaces

It is imperative to determine the suitability of a magner for the task to be Performed. Material thickness and type influence the wll.

Please consult your distributor before purchase.



DISC BRAKE SYSTEM



DUAL SPEED

- Detachable handles
- Black powder- coated finish
- Hand- brake fitted to models 1136
- Disc brake system fitted to models 909B and 1136B
- Designed for deadloade pulls
 - maximum graident 1 in 5
- Models 909B and 1136B are suitable for lifting



SINGLE SPEED

- * 5mm 6x19 FC
- ** 6mm 6x36 IWRC
- *** 8mm 6x36 IWRC

WIRE ROPE WINCHES

A range of wire rope pulling machines with built-in safety features and long lasting durability for industrial applications.

Pull, lift, lower and position with complete safety.



Aluminium Casing Maxiwinch

Maxiwinch wire rope winches are suitable for pulling, lifting, tensioning and releasing in any direction.

Maxiwinches are available in light and compact aluminium and pressed steel construction for applications where aluminium is not recommended.

Maxiwinch wire rope winch are available in different capacities, as shown below with rope lengths made to order

Built-in shearing pin

Prevents overloading. It functions at approx. 25% overload and the pins can be replaced without removing the load.

Backward & Forward levers

Placed in tandem providing a slim design and assuring power transfer along the centre.

Spare shear pins

Two pieces of spare shear pins located in the carrying handle.

Rope clamp system

Easily disengaged with a lever allowing smooth installation of wire rope.

SUGAR & TIMBER BUNDLING SYSTEM



The ideal solution for bundling, transport and stock piling at loading sites and at the mill.

The MaxiGrip is both a tightening and quick release device.



All MaxiGrip components are available separately, including:



50mm Lug Ring



Chain Connecting Link



Clevis Grade 80 Forestry Hook

COMPONENTS

- | | |
|-----------------------|------------------------|
| 1. Side Plate (LH) | 7. Cup Head Rivet - B |
| 2. Side Plate (RH) | 8. Chain Toggle |
| 3. Chain Roller | 9. Trip Toggle |
| 4. Roller Sleeve | 10. Compression Spring |
| 5. Cup Head Rivet - A | 11. Grab Hook |
| 6. Step Pin A | 12. Step Pin - B |

LIFTING & TRANSPORT POINTS



Thiele lifting points serve to create a secure lifting or lashing point to enable safe handling and lashing activities.

The XS Screw Type Lifting Point XL TWN 1890 (EBLRTS)

can be rotated by 360° and swivelled by 180°. The extra wide bow enables easy slinging of bigger hooks. The XS-Lifting point is especially designed for the exchange of the bolts and therefore bolt length.

Grade 100 with 4:1 Safety factor

WARNING: DOES NOT SWIVEL UNDER LOAD!

SCREWED TYPE

EBLRTS - TWN 1890 XS-Lifting Point

XL by Thiele



The Grade 80 Weldable Lifting Point TWN 0119 (LETR)

can be used for lifting and lashing. It is capable of its full working load limit in all directions and can pivot 180°. It can be welded easily and quickly to any steel construction thanks to its pre-aligned weld joint on the weld-on bracket.

Grade 80 with 4:1 Safety factor

WELDABLE

LETR - TWN 0119 Lifting Point

GK8



The TITAN Screw Type Lifting point XL TWN 1120 (EBLR)

has a freely movable coupling link and is capable of lifting its full working load limit in all directions. It rotates easily due to the special bush and guide plate. Grade 100 with 4:1 Safety factor 100% Magnetic crack tested BG approved

WARNING: DOES NOT SWIVEL UNDER LOAD!

SCREWED TYPE

EBLR - TWN 1120 Titan Lifting Point

XL by Thiele



The X-TREME Screw Type Lifting Point XLXL TWN 1830 (EBLRTB)

is equipped with a ball bearing system. It is well suited for loads that have to be turned or flipped. It has a special wide coupling link which enables easy slinging of bigger hooks. The X-TREME Lifting point is not suitable for permanent rotations under load.

SWIVELS UNDER LOAD!

SCREWED TYPE

EBLRTB - TWN 1830 X-TREME Lifting Point

XL by Thiele



Assembled with chain from:

THIELE



Made in Germany



LASHING EQUIPMENT



BINDER CHAIN



LASHING TURNBUCKLE



RATCHET TYPE
LOAD BINDER



GRAB
HOOK



SLIP
HOOK



WELD-ON
TRANSPORT RING



TRUCK
WINCH



LEVER TYPE LOAD
BINDER



RATCHET TENSIONER
COMPLETE WITH STRAPPING

HARDWARE CHAIN

- General purpose welded commercial chain
- Supplied in individual bags of 30M lengths
- Finish: Electro-galvanised or self-colour
- Note: Not to be used for lifting applications



COMMERCIAL SHACKLES

- Bow and Dee commercial shackles
- Material: Mild steel or stainless steel grade 316
- Finish: Electro-galvanised or stainless steel grade 316
- Note: Not to be used for lifting applications

DEE SHACKLE



BOW SHACKLE



QUICK LINKS

- Material: Mild steel or stainless steel grade 316
- Finish: Electro-galvanised or stainless steel grade 316
- Note: Not to be used for lifting applications



CARABINE HOOKS

Insert



Std.



Screw Nut



- Carabine hooks available: standard (plain), with pressed thimble (insert) or with a screw nut
- Material: Mild steel or stainless steel grade 316
- Finish: Electro-galvanised or stainless steel grade 316
- Note: Not to be used for lifting applications



DROP FORGED TURNBUCKLES



Generally to DIN 1480

Available in:

- Eye-Eye (EE) • Hook-Hook (HH) • Eye-Hook (EH)
- Weldable ends (W)
- Material: Drop forged mild steel
- Standard: Generally to DIN 1480
- Finish: Electro-galvanized (Weldable ends: self coloured)

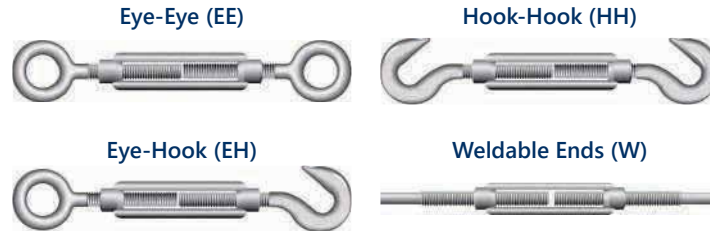

CLOSED BODY RIGGING SCREWS

With Drop-Forged End Fittings & Lock-Nuts

Available in:

- Eye-Eye (EE)
- Jaw-Jaw (JJ)
- Eye-Jaw (EJ)
- Material: Mild steel
- Safety factor: MBL equals 5 x wll
- Finish: Hot dipped galvanized

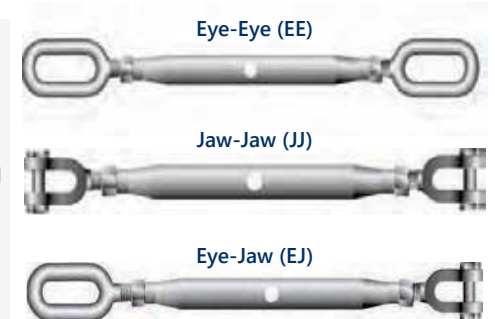

HEAVY DUTY TURNBUCKLES

Generally to ASTM F1145-92

Available in:

- Eye-Eye (EE)
- Jaw-Jaw (JJ)
- Eye-Jaw (EJ)

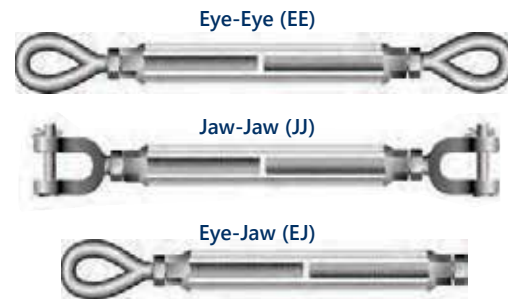

- Material: Drop forged high tensile steel SAE 1035 or 1045
- Safety factor: MBL equals 5 x wll
- Standard: Generally to ASTM F1145-92 (formerly U.S. Federal Specification FF-T- 791b)
- Finish: Jaw Ends have Cotter Pins

DIE CAST TURNBUCKLES

Commercial Quality

Available in:

- Eye-Eye (EE) • Eye-Hook (EH)
- Material: Body - Zinc Die Cast, Hook & Eye-C15 (Bowed)
- Finish: Electro-galvanized

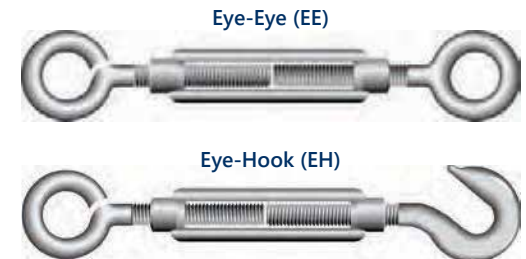

DROP-FORGED EYEBOLTS



to British Standard Specifications (Ungalvanised)



to DIN 582 (Galvanised)

DROP-FORGED EYENUTS



to DIN 582 (Galvanised)

Stainless Steel Eyebolts and Eyenuts

Available in 6, 8, 10, 12, 14, 16, 20, 22 and 24mm Thread sizes

SHACKLES

Green Pin from Van Beest is a premium European manufactured shackle respected worldwide and has become synonymous with exceptional quality, safety and professional reliability.

Green Pin® Standard Shackles

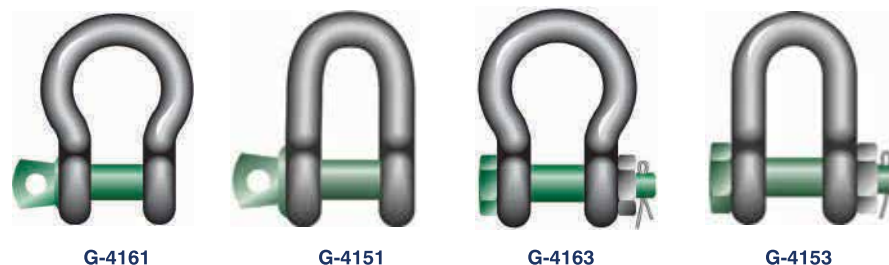

- **Material:** Bow and pin high tensile steel, Grade 6, quenched and tempered
- **Safety Factor:** MBL equals 6 x WLL
- **Standard:** EN 13889 & meets performance requirements of US Fed. Spec. RR-C-271 DNV type approved to certification note 2.7-1
- **Finish:** Hot dipped galvanized
- **Temperature Range:** -20°C up to +200°C
- **Certification:** At no extra charges this product can be supplied with a works certificate, material certificate, manufacturer test certificate and/or EC Declaration of Conformity



SHACKLES & WIRE ROPE CLIPS

Green Pin® Wire rope clips



G-6240

Generally to EN13411-5 Type B

- **Material:** Bridge : Drop forged high tensile steel, SAE 1045, U-bolt : SAE 1015
- **Standard:** : EN 13411-5 Type B Formerly U.S. Federal Specification FF-C-450D
- **Finish:** Hot dipped galvanized nuts for diameter. Bow 5 and 6 mm are electro-galvanized
- **Certification:** A works certificate can be supplied upon request.

Green Pin® Heavy Duty Shackles



G-6036

- **Material:** Bow and pin alloy steel, Grade 8, quenched and tempered
- **Safety Factor:** MBL equals 5 x WLL
- **Finish:** Shackle bow painted silver, pin painted green (120 tons shackle is hot dipped galvanized)
- **Certification:** At no extra charges this product can be supplied with a works certificate, material certificate, manufacturer test certificate, EC Declaration of Conformity and all shackles starting from 150 tons are supplied with a Lloyd's Register of Shipping Certificate on proof load
- **Note:** + 5% forging tolerance on inside width and length

ALLOY DEE & BOW SHACKLES



Lifting shackles generally to US Fed. Spec. RR-C-271



DEE Pin
with Screw



BOW Pin
with Screw



DEE Pin with Bolt,
Nut & Split Pin



BOW Pin with Bolt,
Nut & Split Pin

- Screw Pin and Safety (Bolt, Nut and Split Pin) Shackles
- Safety Factor: 5:1
- Material: Bow and pin high tensile steel, Grade 6
- Standard: Generally to US Fed. Spec. RR-C-271
- Finish: Hot dipped galvanized (Nuts on small sizes electro-galvanized)
- All measurements approximate and subject to tolerances

LARGE DEE SHACKLES

Shackles generally to British Standard Specification B.S. 3032



- Material: Bow and pin alloy steel, EN14a
- Safety Factor: 4:1
- Standard: Generally to B.S. 3032
- Finish: Hot dipped galvanized, electro-galvanized or self colour
- All measurements approximate and subject to tolerances

Large DEE Shackle

Due to our policy of continual product development, dimensions, weights and specifications may change without prior notice. Please check with your sales representative before ordering



CARBON STEEL HOOKS



Lifting shackles generally to US Fed. Spec. RR-C-271



Eye Type



Swivel Type



Shank Type



CARABINE HOOKS
(electro-galvanised and stainless steel)



Sliding Choker
Hooks





ROPE CLAMPS • SHACKLES



Galvanised Drop-forged clamps To ffc-450



Galvanised Malleable cast Rope clamps (Bulldog type) to ffc-450



Galvanised & Stainless steel Malleable cast Rope clamps (Commercial type) to din741 T

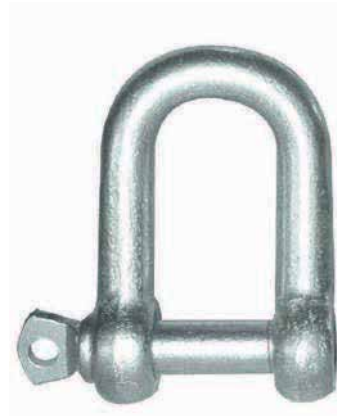

Galvanised, stainless steel and extra long stainless steel Commercial dee shackles



Galvanised and stainless Commercial bow shackles

Commercial shackles are not suitable for lifting applications

SOCKETS • THIMBLES • FERRULES



Open Spelter
Sockets
To bss 463



Closed Spelter
Sockets
To bss 463



Wedge
Sockets



Self-colour
Solid thimbles
To bss 464



Galvanised
Heavy duty Thimbles
To bss 464



Aluminium
Ferrules
To din 3093



Steel
Ferrules



Copper
Ferrules



Galvanised Reaving
thimbles To
bss 464



Galvanised &
Stainless Steel
thimbles To g-411

WIRE GRIPS



0.5t mini-grip
 . 1 to 9.5mm



1t sd grip with safety latch
 . 2,6 to 15mm (small and large eye)



2,3t grip
 . 3,2 to 12,7mm (large eye)



2t grip
 with safety latch
 . 4 to 22mm
 (large eye)

Also available for bare aluminium Conductor
 4 to 22 mm (large eye)



3t grip
 with safety latch
 . 8 to 22mm
 (large eye)
 . 16 to 32mm
 (large eye)

Also available for bare aluminium Conductor
 16 to 32 mm (large eye)



4t grip
 with safety latch
 . 13 to 28mm
 (small eye)
 . 20 to 35mm
 (large eye)

Also available for bare aluminium Conductor
 18 to 35 mm (large eye)



ROPE CUTTERS

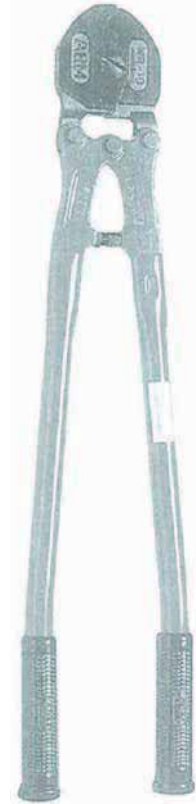

Model wr-10 cuts up to 10mm rope
Model wr-16 cuts up to 16mm rope

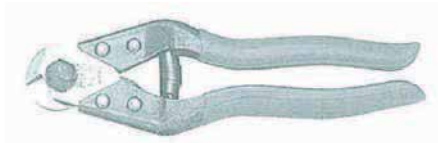

Model rc-8 cuts up to 5mm rope



Spare blade kits

ROPE SWAGERS

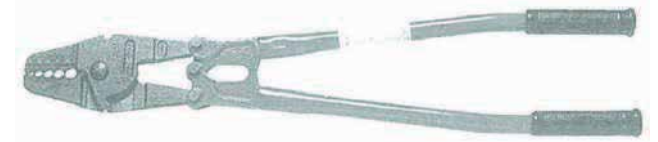

Model hsc - 350 swages 2mm to 3,5 rope
Model hsc - 600 swages 2mm to 5mm rope

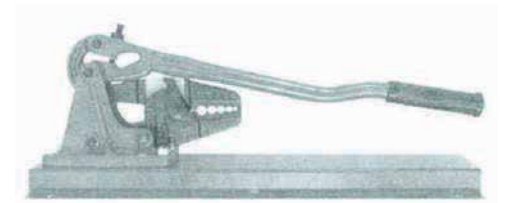

Model hsc - 600bb swa 2mm to 5mm rope
Suitable for large volumes

LEVER PULLERS

Available in 2 ton and 4 ton capacities
Not to be used for lifting

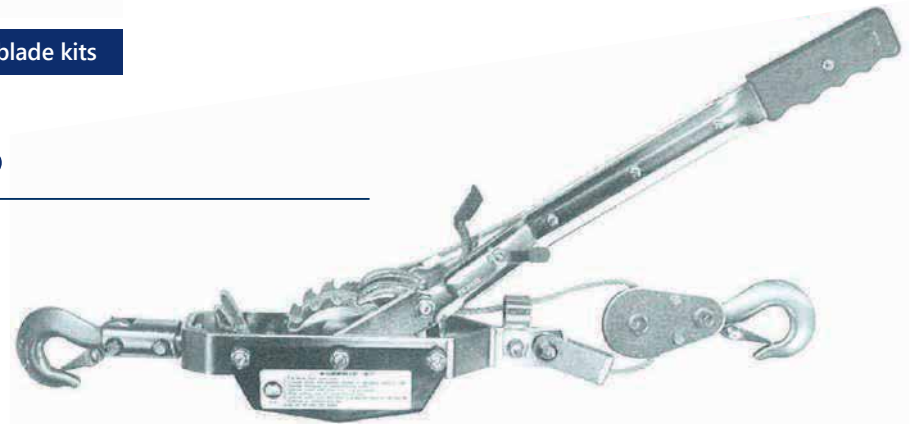

IMPERIAL OFFSHORE
- MARINE SERVICES AND SUPPLY -

FORGED SWIVELS

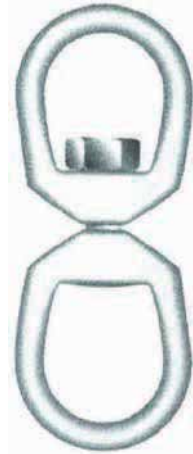

EYE & EYE



EYE & JAW

- These swivels are used for positioning only
- For rotation under load, thrust bearing swivels should be used

THRUST BEARING SWIVELS



EYE & EYE

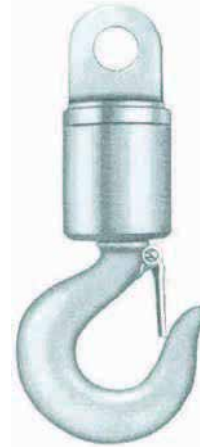

HOOK & EYE



EYE & JAW

- Fitted with grease nipples for lubrication to ensure long life and ease of operation
- These swivels are used for rotation under load

WIRE ROPE BLOCKS



Wire Rope Snatch Blocks

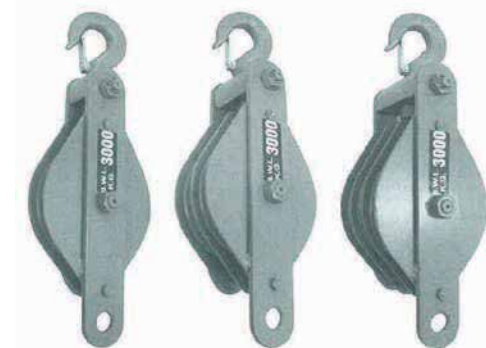

Wire Rope Reeving Blocks

- Snatch blocks available up to 40 ton capacity for use with 38mm diameter steel wire rope
- Reeving blocks available in excess of 100 ton capacity
- Grease nipples for positive lubrication
- Available with forged steel hooks, swivel oval eye, swivel safety shackle, or link and shackle

MANILLA ROPE BLOCKS



GIN Blocks



Pulley Blocks



Running Out Blocks

- Manila pulley blocks available in single, Double and treble sheaves for use with 10mm to 24mm Diameter natural and synthetic fibre ropes
- Gin blocks available in 200kg and 300 kg and 400kg capacities
- 1000 kg running out blocks with nylon sheave wheel



WIRE ROPE SHEAVE WHEELS



- 65mm to 800mm diameters
- Fully machined steel or cast iron
- Phosphor bronze bushes
- Roller or ball bearings available

HAND CHAIN WHEELS

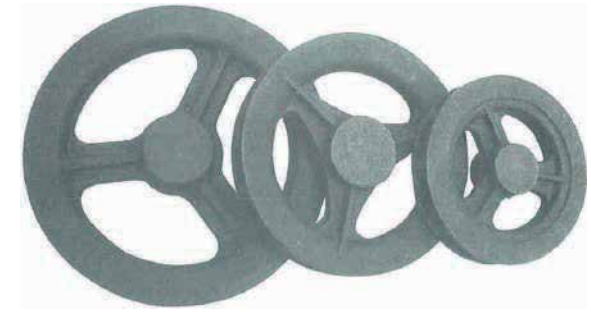

GATOR-FLEX GROMMETS



- Gator-Flex® Grommets are endless for short heavy lift connections. These slings can be made shorter than standard multi-part slings but maintain all the advantages.
- Gator-Flex® Grommets are the most flexible grommet slings in the world. Gator-Laid® products were developed in conjunction with the offshore oil industry to provide the world's best heavy-lift wire rope slings.



ROPE DIVISION

Imperial Offshore supply only quality products at the forefront of innovation. Our ropes are up to date with the latest rope technology like Dyneema, Vectran and Technora.

We can customize your order, or we can provide a list of standard sizes. All Imperial Offshore (PTY) Ltd services comply with ISO 9001 : 2008 accreditation and all specifications conform to British (BS), European (EN) and South African (SABS) standards.



CUSTOM SPECIFICATIONS

All our ropes can be manufactured to custom specifications (reel length, diameter, colour, and materials used can all be varied according to requirements). Please contact us directly for any unique requirements you may have.

BREAK LOAD

Break load is an average result achieved under laboratory conditions, in straight-line pulls with constantly increasing tensile loads. These conditions are rarely duplicated in actual use. Do not use breaking load for design or rating purposes, use safe working load figures.

The breaking load is determined by taking the load that each line in a sample of five breaks and then dividing by five to determine the average breaking load. Break loads may vary slightly for individual reels, but safe working loads will not.

SAFE WORKING LOADS

Because of the wide range of ropes in use, several factors affecting rope behaviour and the degree of risk to life and property involved, it is impossible to make blanket recommendations as to working loads. However, to provide guidelines, working loads are tabulated for rope in good condition with appropriate splices, in non-critical applications and under normal service conditions. Please note that the recommended safe working load for all ropes is one fifth (1/5) of the breaking load.

DYNAMIC LOADS

Normal working loads are not applicable when rope is subject to dynamic loading. Instantaneous changes in load more than 10% of the line's rated working load, constitutes hazardous shock load and would void normal working loads. When a load is picked up, stopped, or swung there is an increased force due to dynamic loading.

The more rapidly or suddenly such actions occur, the greater the increase will be. Examples could be picking up a tow on a slack line or using a rope to stop a falling object. Therefore, in applications such as towing lines, lifelines, safety lines, climbing ropes, etc., given working loads do not apply.

Dyneema®



UHMwPE



REGISTERED TRADEMARKS ®

®Dyneema is a registered trademark of DSM. Technora is a registered trademark of Twaron Teijin.

THE COVER

How to choose the best cover for the right job.

CUSTOM PRODUCTION

- We can make up custom jackets to suit your needs. (Technora , Dyneema , Nomex , PBO , Vectran , Aramid).
- We can make a 24 or 32 carrier jacket.
- For the Classic and Super Yachts we do beige, white, grey and navy solid covers over any of our cores.
- Machine eye splicing available.
- For technical advice and custom production please consult with us.

SNAKE SKIN

- This cover configuration has lines of fibres that create a better dispersion of heat and grip on the winch or in the clutch.

MOTTLED

- The different fibre types are blended together, which assists with heat distribution and abrasion on the winch or in the clutch.

CHAFE COVER

- Offers extra protection where there is extra wear on the rope such as in the clutch or on standing rigging.
- Available in Vectran , Dyneema , PBO and Technora



Different Cover Advantage

TYPES OF FIBRES:

These are the fibres that are the building blocks of the ropes or braids we manufacture. UHMwPE (ultra-high-molecular-weight polyethylene) which is commonly sold under the brand names Dyneema® or Spectra®, also known as HMPE (High Modulus Polyethylene). UHMwPE is very lightweight and extremely strong. The melting point for UHMwPE is 150°C but starts to lose its strength at 65°C.

Aramid refers to Kevlar®, Technora® and Twaron®. Aramid fibres have a very high heat resistance of up to 500°C. Aramid fibres have very low stretch and a low creep.

LCP (Liquid Crystal Polymer) refers to Vectran®. Vectran® breaks down at 330°C with loss of strength above 220°C. Vectran® fibres have very low stretch and low creep.

Zylon (PBO) has a tensile strength which is approximately 1.6 times that of Aramid fibres. Like Kevlar®, Zylon® is used in a number of applications that require very high strength with excellent thermal stability. Zylon® will only start to breakdown at 650°C.

Nomex® has high heat resistance and chemical resistance. Nomex® decomposition rate is only after the temperature exceeds 350°C; however, the material does not melt.

Polyester fibres are used where strength, low stretch and durability is needed. Polyester blends well with other fibres such as the Aramid fibres and makes a very good cover. The melting point of polyester is 260°C but starts to lose its strength at 150°C.

Nylon has good strength and recovery characteristics. Nylon can stretch up to 35% of its length before it will break. Nylon will melt at 220°C but starts to lose its strength at 150°C.

Polypropylene is a low cost and light weight option. Polypropylene melts at 140°C but starts to lose its strength at 90°C.

	Abrasion	Jammer & Winch Grip	Winch Control	Melting Points of fibres:	
Polyester		6	1	UHMwPE	150°C
Nomex - Polyester	2	7	3	Aramid	500°C
Technora® - Polyester	3	10	2	Vectran	330°C
PBO Polyester	5	8	4	Zylon (PBO)	650°C
Technora® - Nomex	3	8	3	Nomex	350°C
PBO	7	9	5	Polyester	260°C
Technora® - PBO	7	8	4		
Technora® - Dyneema®	10	6	2		
Vectran Polyester	3	6	2		

CONSTRUCTION

SPEC 12 (S12)

UHMwPE®



- Range**
- 1 - 9mm
 - White
 - 12 strand single braid UHMwPE yarn that is lightly treated
 - Available raw or with polyurethane coating

- Application**
- Strops
 - Purchase systems
 - Runner tails
 - Control lines

- Features**
- Safer than wire
 - Floats and is Hydrophobic
 - Low creep
 - Easy to splice
 - Highly resistant to UV and most chemicals
 - Internal and external abrasion resistance

SUPER (SUP12)

UHMwPE®



- Range**
- 1 - 60mm
 - Light charcoal, red or blue
 - 12 strand single braid UHMwPE yarn that is heat set
 - Available raw or with polyurethane coating

- Application**
- Strops
 - Halyards
 - Guys and sheets
 - Purchase systems
 - Runner tails

- Features**
- Safer than wire
 - Floats and is Hydrophobic
 - Low creep
 - Easy to splice
 - Very highly resistant to UV and most chemicals
 - Internal and external abrasion resistance

GP 12 (GP12)

Dyneema®



- Range**
- 1 - 60mm
 - Dark charcoal
 - 12 strand single braid Dyneema yarn that is heat set
 - Available raw or with polyurethane coating

- Application**
- High load purchase systems
 - Strops
 - Runner tails
 - Guys and sheets
 - Halyards
 - Check stays
 - Towlines and cables
 - Wire rope replacement
 - Winch lines

- Features**
- Extremely high strength-to-weight ratio
 - Safer than wire
 - Floats and is Hydrophobic
 - Very low creep
 - Easy to splice
 - Highly resistant to UV and most chemicals
 - Internal and external abrasion resistance
 - Coating reduces likelihood of snagging
 - Wire replacement

VEC 12 (V12)

Vectran®



- Range**
- 2 - 20mm
 - 200m reel
 - Available in natural gold colour with purple marker
 - 12 strand single braid Dyneema yarn that is heat set
 - Available raw or with polyurethane

- Application**
- Guys and sheets
 - Halyards
 - Check stays
 - Runner tails
 - Kickers
 - Strops

- Features**
- Zero creep
 - Extremely high strength-to-weight ratio
 - High abrasion resistant
 - High heat resistant
 - Easy to splice
 - Does not float
 - Ultra-low stretch

TECHNICAL: BREAK LOADS

Average break load in kilograms - Larger break loads available on request

Diametre	SPEC 12	SUPER 12	GP 12	VEC 12
1		300		
1.5	250	440	578	
1.75	400	590	704	
2	600	880	1000	750
3	900	1300	1400	1200
3.5	1300	1700	2100	
4	1770	2220	2600	1800
5	2200	3100	3600	2400
6	3000	3900	4700	3400
7	3900	5300	6300	
8	5500	6660	7900	6200
9	6600	8400	10000	
10		9700	11600	9800
11		11500	13700	
12		12600	15100	12600
14		17600	21100	17000
16		21300	27200	22500
17		32200		
18		30000	38300	28500
20		40000	45300	35000

Super 12 total fibre linear density exceeds the ISO 10325 minimum linear density specifications for UHMwPE fibre rope, 12 strand construction specifications for all diameters of each product.

THERMOFIXATION PROCESS OF GRAND PRIX RANGE

The GP Range is made using the latest thermofixation process machinery. The process incorporates a colour treatment and stretching under controlled temperatures with a precise continuous applied load to orientate the molecular chain structure of the UHMwPE fibres in the ideal load direction of the rope.

This process achieves significant improvements in the breakload of the rope and virtually eliminates the 'creep' compared to merely just braiding 'strong' fibres together and applying traditional urethane with heat treatment. This process compacts the yarns and increases the net fibre density of the rope.

Once the core has been braided with the cover it goes through another heat treatment stage to stabilize the cover jacket. This makes the GP Range stronger and more durable than standard production performance ropes on the market.

PERFORMANCE

GP - T BRAID (GPT)

Technora® Dyneema®



Range

- 4 - 24mm
- 200m reels
- Available in different colours with charcoal Technora Red, Navy, Green, Blue, Yellow Classic range in Gold Technora with Beige Polyester

Application

- Sheets and guys
- Halyards
- Out / Downhauls
- Reefing lines
- Runner tails

Features

- 500° C decomposition temperature of Technora
- Ultra-low creep
- Technora prevents slippage in jammer
- Durable on the winch and in blocks

Technical

- Cover: 50% Technora / 50% HT Polyester
- Core: GP12 - Dyneema®
12- Strand single braid Dyneema Urethane coated Heat set
- Construction: Braid on Braid

GP - T BRAID (GPT)

Dyneema®



Range

- 4 - 24mm
- 200m reels
- Available in different mottle colours grey with Red, Navy, Green, Blue, Yellow
- Classic range in Gold Polyester or Beige Polyester

Application

- Sheets and guys
- Halyards
- Out / Downhauls
- Reefing lines
- Runner tails

Features

- Ultra-low creep
- Durable on the winch
- Lightweight
- Abrasion Resistant cover
- UV Resistant Core

Technical

- Cover: 100% HT Polyester
- Core: GP12 - Dyneema®
12- Strand single braid Dyneema Urethane coated Heat set
- Construction: Braid on Braid

VECTRAN BRAID (VB)

Vectran®



Range

- 4 - 24mm
- 200m reels
- Available in different colours Red, Blue, Green, Yellow
- Classic range in Gold Vectran with Beige Polyester

Application

- Sheets and guys
- Halyards
- Runner tails
- Control line

Features

- Zero creep
- Ultra-low creep
- Durable on the winch and in blocks
- Extremely high strength-to-weight ratio
- Polyester sheath prevents block and jammer slippage
- High abrasion resistance

Technical

- Cover: 100% HT Polyester
- Core: Vec 12 - Vectran®
12- Strand single braid Vectran Urethane coated Heat set
- Construction: Braid on Braid

SUPER TW BRAID (STW)

Vectran®



Range

- 4 - 24mm
- 100m & 200m reels
- Available only with Charcoal/Gold Technora Mottle

Application

- Halyards
- Reefing lines
- Control lines
- Sheets and guys
- Traveller lines

Features

- 500° C decomposition temperature of Technora
- Ultra-low creep
- Technora prevents slippage in jammer
- Very high abrasion qualities

Technical

- Cover: 100% HT Technora
- Core: Super 12
12- Strand single braid Vectran Urethane coated Heat set
- Construction: Braid on Braid

TECHNICAL: BREAK LOADS

Kilograms - Larger break loads available on request.

MM	4	5	6	7	8	9	10	12	14	16	18	20	22	24
GP - T BRAID	1000	1500	2100	3600	4700	6300	7900	11600	15000	21000	27200	32000	38300	45300
GP BRAID	1000	1500	2100	3600	4700	6300	7900	11600	15000	21000	27200	32000	38300	45300
VECTRAN					3650		5840	7500	10100	11950	14500	18800	21500	25300



YACHTING

SUPER T BRAID (SUPT)

Technora®



- Range**
- 4 - 24mm
 - 200m reels
 - Available in different colours with Charcoal or Gold Technora Red, Navy, Green, Blue, Yellow

- Application**
- Halyards
 - Reefing lines
 - Control lines
 - Sheets and guys
 - Traveller lines

- Features**
- 500° C decomposition temperature of Technora
 - Ultra-low creep
 - Technora prevents slippage in jammer
 - Durable on the winch and in blocks

- Technical**
- Cover: 50% Technora / 50% HT Polyester
 - Core: Super 12
12- Strand single braid UHMwPE Urethane coated Heat set
 - Construction: Braid on Braid

SUPER BRAID (SUPB)

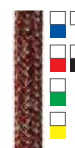

- Range**
- 4 - 24mm
 - 200m reels
 - Available in mottled colours - Blue, Red, Green, White, Yellow, Black
 - Solid colours available on request: Grey, White, Beige, Navy

- Application**
- Halyards
 - Reefing lines
 - Control lines
 - Sheets and guys
 - Traveller lines

- Features**
- Lightweight
 - Low creep
 - UV Resistance Core
 - Polyester sheath prevents block and jammer slippage

- Technical**
- Cover: HT Polyester
 - Core: Super 12
12- Strand UHMwPE yarn Urethane coated Heat set
 - Construction: Braid on Braid

SPECTRA SPEED (SPB)

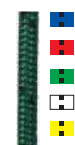

- Range**
- 2 - 24mm
 - 200m reels
 - Available in solid colours with a black marker fleck - Blue, Red, Green, White, Yellow

- Application**
- Halyards
 - Sheets
 - Control lines
 - Runner Tails
 - Reefing lines

- Features**
- Lightweight
 - Low creep
 - UV Resistance Core
 - Polyester sheath prevents block and jammer slippage
 - Good for cruising yachts

- Technical**
- Cover: HT Polyester
 - Core: Spec 12
White
 - Construction: Braid on Braid

YACHTMASTER (RB)



- Range**
- 6 - 24mm
 - 200m reels
 - Available in solid colours - Red, Green, Blue, Yellow, Black, Grey, White, Beige, Navy or White with fleck
 - Blue, Red, Green, White, Yellow, Black

- Application**
- Halyards
 - Reefing lines
 - Control lines
 - Sheets and guys
 - Traveller lines

- Features**
- Low creep
 - High tenacity and abrasion resistance
 - High resistancy to UV and most chemicals

- Technical**
- Cover: HT Polyester
 - Core: HT Polyester Braid
 - Construction: Braid on Braid

TECHNICAL: BREAK LOADS

Kilograms - Larger break loads available on request.

MM	2	3	4	5	6	7	8	9	10	12	14	16	18	20	22	24
SUPER T BRAID					1770	3100	3990	5320	6660	9760	12600	17640	21380	26130	30090	40390
SUPER BRAID					1770	3100	3990	5320	6660	9760	12600	17640	21380	26130	30090	40390
SPECTRA SPEED	280	440	590	1184	1330		3100		5320	8436						
YACHTMASTER							1700		2350	3250	4200	5600	7800			

SMOOTH CONTROL

SUPER LITE (DL)

Smooth Control



- Range**
- 3,4,5, 6mm
 - 100m to 200m reels
 - Available in multiple colour combinations

- Application**
- Halyards
 - Sheets
 - Control lines
 - Out / Downhauls
 - Kickers

- Features**
- Lightweight
 - Low stretch
 - Abrasion resistant

- Technical**
- Cover: HT Polyester
 - Core: HT Polyester / UHMWPE parallel yarns
 - Construction: Cover-on-Braid

LASER LINE (LL)



- Range**
- 2 - 8mm
 - 100m to 200m reels
 - Available in assorted colours with a triple fleck

- Application**
- Control lines
 - General applications where stretch is not critical

- Features**
- Limited water absorption
 - Good strength

- Technical**
- Core: Polyester
 - Cover: 16 plait MFP
 - Construction: Braid-on-Braid

SUPER T BRAID (SUPT)



- Range**
- 4 - 24mm
 - 200m reels
 - Available in different colours with charcoal Technora Red, Navy, Green, Blue, Yellow

- Application**
- Halyards
 - Reefing lines
 - Control lines
 - Sheets & guys
 - Traveller lines

- Features**
- 500° C decomposition temperature of Technora®
 - Ultra-low creep
 - Technora prevents slippage in jammer
 - Durable on the winch and in blocks

- Technical**
- Cover: 50% Technora® / 50% HT Polyester
 - Core: Super 12
12 strand single braid UHMWPE Urethane coated Heat set
 - Construction: Braid on Braid

SPECTRA SPEED (SPB)



- Range**
- 2 - 24mm
 - 200m reels
 - Available in solid colours with a black marker fleck - Blue, Red, Green, White, Yellow

- Application**
- Halyards
 - Sheets
 - Control lines
 - Runner tails
 - Reefing lines

- Features**
- Lightweight
 - Low creep
 - UV resistance core
 - Polyester sheath prevents block and jammer slippage
 - Good for cruising yachts

- Technical**
- Cover: HT Polyester
 - Core: Spec 12 White
 - Construction: Braid on Braid

TECHNICAL: BREAK LOADS

Kilograms - Larger break loads available on request.

MM	2	3	4	5	6	7	8	9	10	12	14	16	18	20	22	24
SUPER LITE		175	300	450	500											
LASER LINE	120	250	375	490	585	700	900									
SUPER T BRAID		560	990	1550	1770	3100	3990	5320	6660	9760	12600	17640	21380	26130	30090	40390
SPECTRA SPEED	280	440	590	1184	1330		3100		5320	8436						



SHEETS & CONTROL LINES

MARSTRAND (MAR)

 <p>Range</p> <ul style="list-style-type: none"> • 5 - 10mm • 100m to 200m reels • Available in different mottled colours - Blue, Red and Yellow 	<p>Application</p> <ul style="list-style-type: none"> • Sheet lines • Rescue lines 	<p>Features</p> <ul style="list-style-type: none"> • Soft and easy to handle • Floats • Hydrophobic • UV Resistant 	<p>Technical</p> <ul style="list-style-type: none"> • Cover: Multi-filament Polypropylene • Core: Multi-filament Polypropylene & Parnell yarn • Construction: 8 plait 16 plait
---	---	---	--

SHEETLINE (ZS 75)

 <p>Range</p> <ul style="list-style-type: none"> • 6mm • 100m to 200m reels • Available in mottled Red 	<p>Application</p> <ul style="list-style-type: none"> • Laser mainsheet 	<p>Features</p> <ul style="list-style-type: none"> • Grippy • Hard wearing polyester cover 	<p>Technical</p> <ul style="list-style-type: none"> • Cover: Polyester and Spun Polyester • Core: 12 Strand UHMWPE • Construction: Braid on Braid
---	---	---	---

SHEETLINE LIGHT (ZS 75 LITE)

 <p>Range</p> <ul style="list-style-type: none"> • 5.5mm • 100m to 200m reels • Available in mottled Yellow 	<p>Application</p> <ul style="list-style-type: none"> • Extreme lightweight mainsheet 	<p>Features</p> <ul style="list-style-type: none"> • Grippy • Non-absorbent Floats • Lighter 	<p>Technical</p> <ul style="list-style-type: none"> • Cover: Multifilament + Spun Polyester • Core: 12 Strand UHMWPE • Construction: Braid on Braid
--	---	--	---

XD LIGHT NON TWIST (XDL)

 <p>Range</p> <ul style="list-style-type: none"> • 6.5mm - 9mm • 100m to 200m reels • Available in blue with a yellow fleck 	<p>Application</p> <ul style="list-style-type: none"> • Lengthy mainsheet 	<p>Features</p> <ul style="list-style-type: none"> • Non-rotating • Non locking • Easy to handle line 	<p>Technical</p> <ul style="list-style-type: none"> • Cover: HT Polyester • Core: Multifilament 12 strand • Construction: A blend of Fibrebrite polyester and multifilament fibres
--	---	---	--

TECHNICAL: BREAK LOADS

Kilograms - Larger break loads available on request.

MM	4	5	5.5	6	8	9
MARSTRAND	1450	2100		3360	7680	
SHEETLINE				720		
SHEETLINE LIGHT			720			
XD LITE				860	1200	1450

CONTROL LINES

DYNALOCK (DYL)



- Range**
- 4 - 6mm
 - 100m to 200m reels
 - Available in black, blue and yellow colour combinations

- Application**
- Control lines
 - Sheets
 - Halyards
 - Out / Downhauls
 - Reefing lines
 - Kickers

- Features**
- Low creep
 - Abrasion resistant

- Technical**
- Cover: HT 8-plait Polyester
 - Core: UHMwPE
 - Construction: Braid-on-Braid

VECLOCK (VL)



- Range**
- 4 - 6mm
 - 100m to 200m reels
 - Available in black, red and yellow colour combinations

- Application**
- Control lines
 - Sheets
 - Halyards
 - Rope that is under constant tension, which should not elongate over time.

- Features**
- Low creep
 - Abrasion resistant

- Technical**
- Cover: HT 8-plait Polyester
 - Core: Vectran
 - Construction: Braid-on-Braid

POLYLOCK (PL)



- Range**
- 4 - 8mm
 - 100m to 200m reels
 - Available in black, red and white colour combinations

- Application**
- Halyards
 - Sheets
 - Control lines
 - Out / Downhauls
 - Kickers

- Features**
- Limited water absorption
 - Low creep
 - Abrasion resistant

- Technical**
- Cover: HT 8-plait Polyester
 - Core: 8 plait Polyester
 - Construction: Braid-on-Braid

TITAN BRAID (T)



- Range**
- 2 - 6mm
 - 100m to 200m reels
 - Available in white with a black marker and solid white

- Application**
- Keel boat leech lines
 - Control lines
 - Sheets
 - Halyards
 - Out / Downhauls

- Features**
- Abrasion resistant
 - UV resistant
 - Low friction
 - Ultra low stretch
 - Low creep

- Technical**
- Cover: UHMwPE
 - Core: HT Braided Polyester
 - Construction: Braid-on-Braid

TECHNICAL: BREAK LOADS

Kilograms - Larger break loads available on request.

MM	3	4	5	6	8
DYNALOCK		350	540	770	
VECLOCK		350	540	770	
POLYLOCK		360	590	780	1350
TITAN BRAID	400	500	720	1100	

MOORING LINES

POLYESTER (PS)



- Range**
- 6 - 46mm
 - 200mm reels
 - Available in White, Navy Blue, Olive Green, Burgundy and other colours on request

- Application**
- Anchor lines
 - Mooring lines
 - Lanyards
 - Fender lines
 - Towing lines
 - Net frame ropes
 - General purpose industrial ropes

- Features**
- BS EN 697:1995
 - Strength not affected by water
 - Does not shrink
 - UV resistant
 - Abrasion resistant
 - Sinking rope

- Technical**
- Material: HT Polyester
 - Construction: 3 Strand Hawser Lay

NYLON (PA)

- Range**
- 3 - 44mm
 - 200mm reels
 - Available in White

- Application**
- Anchor lines
 - Mooring lines
 - Towing lines
 - Fishing lines
 - Kinetic ropes
 - Parachute anchor lines

- Features**
- BS EN 943:2002
 - Sinking rope
 - Excellent Stretch and recovery characteristics

- Technical**
- Material: Nylon/Polyester
 - Construction: 3 strand

MULTIFILAMENT (MFPP)

- Range**
- 2 - 16mm
 - 200m reel
 - Available in solid colours and colour combinations

- Application**
- General purpose
 - Draw cords
 - Decorative cords
 - Retaining cords
 - Tie-downs
 - Light duty control lines

- Features**
- Lightweight
 - Soft hand
 - Floats

- Technical**
- Round:
 - Cover: Multifilament Polypropylene
 - Core: None
 - Construction: Single Braid
 - Flat:
 - Cover: Multifilament Polypropylene
 - Core: Multifilament Polypropylene
 - Construction: Braid on Twist

TECHNICAL: BREAK LOADS

Kilograms - Larger break loads available on request.

MM	2	3	4	5	6	8	10	12	14	16	18	20	22	24	26	28
POLYESTER					850	1450	2290	1450	4400	6000	7000	8400	10800	12500	14250	16500
NYLON					750	1350	2080	3000	4100	5300	6700	8300	10000	12000	13900	15800
MULTIFILAMENT	110	200	325	420	500	1020	1590	2250	3180	4060	5080					

More break loads available on request

MOORING

ANCHOR BRAID - (OCTOPLAIT) (PS8)



Range

- 12 - 32mm
- 20kg reels
- Available in White

Application

- Anchor lines
- Mooring lines
- Towing lines
- Drogue lines
- Children's toys

Features

- Low stretch
- High tenacity
- Abrasion resistance
- High resistivity to UV and most chemicals

Technical

- Material: HT Polyester or Nylon
- Construction: 8 Single Braid

Manufacture according to BS/EN 71-2:2003 (Flammability) BS/EN 71-3:1995 Incl. A1:2000, for the use in children toys.

DOCK LINE (MDL)



Range

- 10 - 36mm
- 220m reels
- Available in black, navy and white

Application

- Mooring lines
- Fender lines
- Painter lines

Features

- Durable
- Excellent stretch recovery
- Easy to handle
- Easy stowing

Technical

- Cover: HT Polyester
- Core: Nylon
- Construction: Braid-on-Braid

DOCK LINE PACKS (PB)



Range

- 10mm, 12mm, 14mm in 10m or 15m lengths with a 30cm eye splice
- Available in black, navy and white

Application

- Mooring lines

Features

- Easily attached to the bollard when mooring as there is a eye splice in the end of the line.

Technical

- Cover: HT Polyester
- Core: Nylon
- Construction: Braid-on-Braid

FENDER LINES (FL)



Range

- 8mm fender line in 2 metre lengths with a 50cm eye splice in packs of 2
- Available in black, navy and white

Application

- Fender lines

Features

- Easy to attached to the fender with the spliced loop

Technical

- Material: HT Polyester
- Construction: 3 strand

TECHNICAL: BREAK LOADS

Kilograms - Larger break loads available on request.

MM	10	12	14	16	18	20	22	24	26	28	30	32
ANCHOR BRAID		3795	4840	6600	7700	8140	11880	13750	15675	18150	20570	22880
DOCK LINE	2550	3500	5000	6575	8100	10000	12100	14400	16900	19600		

ACCESSORIES

BURGEE CORD (BC)

	Range • 2 - 12mm • 100m reels • Available in solid colour	Application • Flag halyards • Mouse lines • Boat cover tie downs • Tie downs Nets	Features • Rigid construction • Low creep • Abrasion resistance • UV Resistance	Technical • Cover: Braided polyester • Core: Parallel strands of polyester						
Diametre (mm)	2	3	4	5	6	7	8	10	12	14
Burgee Cord	150	300	480	540	700	950	1255	1935	2790	3800

Kilograms - Larger break loads available on request.

MOUSE LINE (MFPP)

	Range • 3mm, 500m reels	Application • Mouse lines	Features • Rigid construction	Technical • Braided multifilament
--	-----------------------------------	-------------------------------------	---	---

SHOCK CORD (SC)

	Range • 3 - 10mm • 100m reels • Available in solid colours and white with colour flecks.	Application • Securing objects • Tie downs • Nets	Features • Minimum of 100% stretch • Excellent recovery from stretch	Technical • Cover: Polyester • Core: Rubber • Construction: Braid over parallel core
--	--	---	---	--

CHAFE COVER (DCC/TCC)

	Range • 6 - 8mm • 10 - 12mm • 14 - 16mm • 18 - 20mm • 100m reels	Application • Protection of sheets and halyards in high abrasive areas	Technical • Material: Dyneema or Vectran or Technora • Construction: Single cover braid
--	--	--	--

HOT KNIFE (2700)



This industrial hot knife rope cutter is a hand operated tool that you plug into the wall. Once hot it will cut and seal the ends on all synthetic cords and ropes. It takes a mere 6-8 seconds to heat up to approx 600°C it will melt the rope and seal the ends. Heat may be controlled by switching tool on and off. This tool will save you both time and money compared to mechanical cutting, your ropes will last longer and the cutting process is quicker. The Hot Knife comes with a blade for cutting and sealing rope.

SELMA SPLICING FIDS (8230)

This set of 5 Selma fids are made from highly polished stainless steel, but the very large fid is made from nicol plated brass. They are used for splicing double braids, 3-strand construction ropes and hollow braids ropes. They come in a protective case complete with detailed illustrated instructions for splicing loop splices, eye splices, back splices & end-to-end splices.

DYNEEMA® WHIPPING TWINE



Range • 0.5mm, 1mm & 1.5mm Dyneema waxed whipping twine	Application • Whipping the end of the rope	Features • Extremely high strength-to-weight ratio • Low Creep • Very high resistance to uv and most chemicals • Coating reduces likelihood of snagging	Technical • Material: Heat-set Dyneema braid and waxed • Construction: 12 strand single braid
--	--	--	--

WATER SPORTS

KITE LINE (K)



	Range • 0.5mm • 1mm • 1.5mm • 500m to 1000m reels • Available in raw (white) or with polyurethane coating* (black)	Application • Kite Line	Features • High tensile strength • Lightweight • Floating	Technical • Material: UHMwPE • Construction: 12 strand single braid
--	--	-----------------------------------	---	--

SKI ROPE

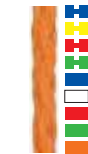

	Range • 5 - 18mm • 100m or 200m reels • Available in solid and white colour combinations	Application • Towing rope for water sports • Rescue line • Nets • Tie-downs • General Purpose	Features • Loose construction promotes easy splicing • Lightweight • Durable • Floats	Technical • Material: Polyethylene • Construction: Single Braid
--	--	---	--	--

RESCUE ROPE (BP)



	Range • 6mm, 8mm & 10mm • 200m reels • Available in yellow with red fleck and red with yellow fleck	Application • Ideal for safety rope	Features • Lightweight • Easy to handle • Floating line • High Visibility	Technical • Material: Multifilament Polypropylene rope • Construction: Braid 8 plait
--	---	---	--	---

KITE LINE

Diametre (mm)	Reel Size (M)	M/KG	Break Load (KG)
0.5	1000	2562	90
1	1000	1315	180
1.5	1000	625	320

SKI ROPE

Diametre (mm)	Reel Size (M)	M/KG
5	10	110
7	10	65
10	10	32
12	10	20

RESCUE ROPE

Diametre (mm)	6	8	10
KG	600	900	1350



The leading edge of excellence

www.imperialoffshore.com